

CI/SfB	(31)	Zt4
CAW P10		
Uniclass L675:P91		

Description

TP600 is a soft and flexible open cell polyurethane foam, impregnated with an acrylic based, UV stabilised resin. The resin is water repellent and contains a fire retardant. It is supplied as pre-compressed rolls with a self-adhesive side to aid initial location. Weather tight against the most severe combinations of wind and rain, it satisfies most expectations as an external weather seal for window perimeter seals and in building and civil engineering applications. With full BBA approval, the product has been extensively tested and has a proven reputation across both the UK and Europe. (Cert. 96/3309)

Colour

Anthracite and grey

Standard Sizes

Joint / Gap Size to be Filled mm (a)	Joint Depth / Tape Width mm (b)	Tape Order Reference	Roll Length (m)
2	10	10 / 2	12.5
3	10	10 / 3	10
3	20	20 / 3	10
3- 7	10	10 / 3-7	8
3- 7	15	15 / 3-7	8
3- 7	20	20 / 3-7	8
5- 10	10	10 / 5-10	5.6
5- 10	15	15 / 5-10	5.6
5- 10	20	20 / 5-10	5.6
7- 12	15	15 / 7-12	4.3
7- 12	20	20 / 7-12	4.3
7- 12	25	25 / 7-12	4.3
8- 15 [□]	15	15 / 8-15	3.3
8- 15	20	20 / 8-15	3.3
8- 15	30	30 / 8-15	3.3
10- 18	20	20 / 10-18	4.5
10- 18	25	25 / 10-18	4.5
10- 18	30	30 / 10-18	4.5
13- 24 [□]	25	25 / 13-24	5.2
13- 24	30	30 / 13-24	5.2
17- 32 [□]	30	30 / 17-32	4
17- 32	35	35 / 17-32	4
22- 40	40	40 / 22-40	2.7

[□] These sizes are available only in the UK

Tape Selection

- The tape should be selected so that the roll width (joint depth) is at least equal to the tape thickness (joint width) in service.
- For applications outside of this instruction, please consult our sales office.



TP600

Compriband 600

Usage / Purpose

TP600 is an impregnated joint sealing tape for use in a wide variety of movement joints including window perimeter seals and other applications.

Key Benefits

- 15 year performance guarantee
- Weather seal for wind-driven rain
- Breathable – for vapour diffusion
- Continually expands and contracts to accommodate movement whilst still sealing the joints
- Thermal and acoustic insulation



"i3" Window Sealing System; Part of the state of the art, ift-approved sealing system, with a 15 year guarantee.* This system fulfils the EnEV requirements with regards to airtightness.; *Under the conditions specified by the manufacturers. Only valid on receipt of the correct registration documents in accordance with terms and conditions, available on request.



BBA Accredited Certificate N° 96/3309 and Certificate N° 12/4891 as part of the i3 system.

Compriband 600

Technical Information

Property	Test Method	Result
Building Classification	DIN 4102	B1, self-extinguishing, P-NDS 04-229
Exposure Class for Impregnated Foam Tapes	DIN 18542	BG1
Thermal Conductivity	DIN 52612	$\lambda_{10} < 0.048 \text{ W/m/K}$
Vapour Resistivity	DIN 52615	$\mu < 100$
Resistance to Root Penetration	DIN 4062	The requirements of DIN standards are met
Air Permeability	DIN 18542	$\alpha < 1.0 \text{ m}^3 / [\text{h.m.}(\text{daPa})^2/3]$
Weathertight Against Driving Rain	DIN 18542 / DIN EN 1027	The requirements of the DIN standard are met up to the described joint sizes, giving a minimum of 600 Pa, independently supervised by MPA Hannover
Compatibility with Conventional Construction Materials	DIN 18542	No signs of corrosion observed on iron, zinc, steel, galvanised steel, aluminium, and copper. No adverse effects with concrete, aerated concrete, brick, some stones, PVC, Plexiglas or timber
Life Expectancy		> 25 years
Performance Guarantee		15 year warranty* on performance
Service Temperature		-30°C to +90°C
Storage		Store rolls horizontally and in original carton between +1°C and +25°C in dry conditions and away from direct sunlight. Re-seal packaging between use to prevent expansion during storage.
Shelf Life		2 years when stored in its original unopened containers.

* Under the conditions specified by the manufacturers. Only valid on receipt of the correct registration documents in accordance with terms and conditions, available on request.

Application

- After measuring the width of the joint and ensuring the total movement is within the capacity of the selected tape size, application may proceed.
- Remove outer release liner and the opening wedge at the start of the roll.
- If installing tape into a construction joint with a cross-joint, it may initially be applied either horizontally or vertically (from bottom to top to avoid stretching of the tape). However, when applying to a door or window frame the horizontal seals must be applied before the vertical ones (Fig. 1). Tape must be applied with the adhesive side to the frame when working with fenestration but may be applied in any order when working with construction joints. In both cases do not stretch the tape. When working in damp or cold conditions, if the tape is not adhering to the joint face, a suitable wedge should be used to hold the tape in position until it is expanded. Ensure the tape is recessed by a minimum of 2 mm into the joint. (Fig. 4).
- When calculating the length of tape to be fitted, add 20 mm/m to the actual joint length. Be sure to measure the opening and not the window.
- At the end of a roll, cut off the tape wedge finish. Repeat the process with a new roll, making a close compressed butt connection as shown in Fig. 2. At cross of crucifix joint, install as per Fig. 3.
- If the seal is to be tested using the CWCT (TN41) hose test, we recommend a minimum tape width of 25 mm. The tape should be allowed 7- 10 days conditioning in the joint before testing.
- When installing TP600 between a window and a sloping sub-sill, the joint must be no more than 5° out of parallel. The TP600 should be applied to the 'level' face of the joint.
- When inserting the tape into a joint with difficult access or when making butt or corner joints, the use of a skewer inserted into the tape thickness close to the end of the length to be applied allows the tape to be more accurately located.
- When applying PU foam behind TP600, prior to application, ensure that the tape has fully expanded to seal the joint otherwise foam is likely to penetrate past the edge of the tape and will be visible on the external face.

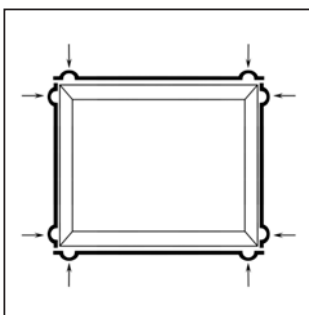

Fig. 1
Tape application at corners
Note oversize length 10 mm/m
Install small loop to ensure sufficient length

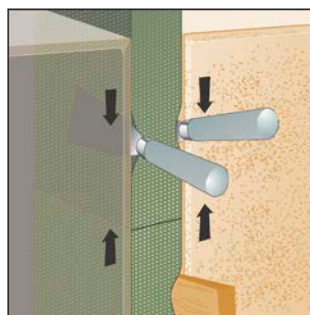

Fig. 2
Compression of tape to make weather-tight butt joints

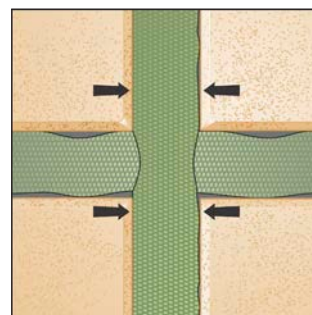

Fig. 3
Compression of tape to make weather-tight cross joints

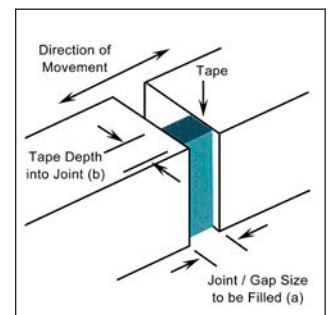

Fig. 4
Tape Selection
(a) = tape thickness; (b) = tape width
eg 15/8- 15; 15 (b) /8- 15 (a)

TP600

Compriband 600

TP600 Application Guide

Tape width/thickness range (mm)	10/2	15/3	15/3-7	15/5-10	15/7-12	20/8-15	20/10-18	30/13-24	35/17-32	40/22-40
2	Light Green									
3	Orange	Light Green	Dark Green							
4	Orange	Light Green	Dark Green							
5		Orange	Light Green	Dark Green						
6		Orange	Light Green	Dark Green						
7			Light Green	Dark Green	Dark Green					
8			Orange	Light Green	Dark Green	Dark Green				
9			Orange	Light Green	Dark Green	Dark Green				
10				Light Green	Dark Green	Dark Green	Dark Green			
11				Orange	Light Green	Dark Green	Dark Green			
12				Orange	Light Green	Dark Green	Dark Green			
13				Orange	Orange	Light Green	Dark Green	Dark Green		
14				Orange	Orange	Light Green	Dark Green	Dark Green		
15				Orange	Orange	Light Green	Dark Green	Dark Green		
16					Orange	Orange	Light Green	Dark Green	Dark Green	
17					Orange	Orange	Light Green	Dark Green	Dark Green	
18					Orange	Orange	Light Green	Dark Green	Dark Green	
19					Orange	Orange	Light Green	Dark Green	Dark Green	
20					Orange	Orange	Light Green	Dark Green	Dark Green	
21					Orange	Orange	Light Green	Dark Green	Dark Green	
22						Orange	Light Green	Dark Green	Dark Green	Dark Green
23						Orange	Light Green	Dark Green	Dark Green	Dark Green
24						Orange	Light Green	Dark Green	Dark Green	Dark Green
25							Orange	Light Green	Dark Green	Dark Green
26							Orange	Light Green	Dark Green	Dark Green
27							Orange	Light Green	Dark Green	Dark Green
28							Orange	Light Green	Dark Green	Dark Green
29							Orange	Light Green	Dark Green	Dark Green
30							Orange	Light Green	Dark Green	Dark Green
31								Orange	Light Green	Dark Green
32								Orange	Light Green	Dark Green
33								Orange	Light Green	Dark Green
34								Orange	Light Green	Dark Green
35								Orange	Light Green	Dark Green
36								Orange	Light Green	Dark Green
37								Orange	Light Green	Dark Green
38								Orange	Light Green	Dark Green
39								Orange	Light Green	Dark Green
40									Orange	Light Green
to 50									Orange	Light Green
to 80										Orange

KEY

- Application as a weather seal to min. 600 Pa; thermal insulation; acoustic insulation
- Application as a weather seal to 750 Pa; thermal insulation; acoustic insulation
- Application as a weather seal to 900 Pa; thermal insulation; acoustic insulation
- Application as thermal insulation; draughts



Please Note

- TP600 is not suitable for locations where standing water or a head of water is likely to occur, eg under a window fixed on a flat topped sub-sill where the tape is not within 2-3 mm of the vertical face of the sub-sill.
- High temperatures accelerate tape expansion, while low temperatures delay this. At ambient temperatures above 20°C, the tape should be stored in a cool place on the construction site away from direct sunlight. A small fridge is ideal for this.
- Remaining rolls in opened boxes should be maintained in a horizontal state and weighed down to prevent lateral expansion (telescoping) of the rolls. Whilst it is unnecessary to seal over the external face of the tape, the exposed edge can be plastered or painted over. The compatibility of sealants must be tested. In some cases, white sealants can be incompatible. The tape must not come into contact with chemicals containing solvents or aggressive chemicals.

Health & Safety Precautions

Safety data sheet must be read and understood before use.



Technical Service

tremco illbruck has a team of experienced Technical Sales Representatives who provide assistance in the selection and specification of products. For more detailed information, service and advice, please call Customer Services on 01942 251400.

Guarantee / Warranty

tremco illbruck products are manufactured to rigid standards of quality. Any product which has been applied (a) in accordance with tremco

illbruck written instructions and (b) in any application recommended by tremco illbruck, but which is proved to be defective, will be replaced free of charge.

No liability can be accepted for the information provided in this leaflet although it is published in good faith and believed to be correct. tremco illbruck Limited reserves the right to alter product specifications without prior notice, in line with Company policy of continuous development and improvement.



tremco illbruck Limited
Coupland Road, Hindley Green
Wigan WN2 4HT
United Kingdom
T: +44 1942 251400
F: +44 1942 251410

sales.uk@tremco-illbruck.com
www.tremco-illbruck.co.uk